

RR + LB  
AWWA  
RRDS

## 10th Annual R+D Awards

INTRODUCTION BY WANDA LAU

TEXT BY NATE BERG AND GIDEON FINK SHAPIRO

World hunger. Climate change. Natural disasters. Conservation. Anyone who questions architecture's relevance to the big issues should look no further than the 14 recipients of this year's R+D Awards, ARCHITECT's annual celebration of innovative research and technology. From 100 submissions, jurors Mic Patterson, Doug Stockman, AIA, and Elizabeth Whittaker, AIA, selected five winners, five citations, and four honorable mentions, all by impassioned, interdisciplinarily minded designers using advanced computation and fabrication technologies to tackle problems of all scales and scopes.

This year marks the R+D Awards' 10th anniversary, but we're not patting ourselves on the back. One decade is but a blip in the history of human habitation. We are content to help provide, as one of this year's recipients describes it, "validation that all the time spent working on this project has meant something."

# WINNER

Cricket Shelter and Farm







For the exhibition “Survival Architecture and the Art of Resilience,” organized by the Oakland, Calif., nonprofit Art Works for Change, Mitchell Joachim, ASSOC. AIA, envisioned a structure that would provide not only shelter, but also a source of sustenance that could endure climate change and natural disasters. The food source? Crickets, whose protein-rich bodies require little water and energy to grow. “They’re good for you and good for the planet,” says Joachim, the co-founder of Brooklyn, N.Y.-based [Terreform ONE](#) and an associate professor of practice at New York University.

Ultimately, [Terreform ONE](#)’s prototype cricket shelter and farm is less about providing emergency relief, and more about experimenting with food culture and ecology through architecture. Currently cricket protein is ground up in energy bars that “taste like wood,” Joachim says. He suggests that the insect could be integrated into refined dining culture and cuisine, similar to how sushi took off in the U.S. in the 1980s. And crickets can—and should—be grown and harvested locally, he says, to match the farm-to-table

values of today’s eco-conscious gourmands.

Crickets have long been farmed in several countries, Joachim says, but the standard practices are unsanitary because they do not effectively screen out carcasses, baby crickets, feces, and dirt. In contrast, [Terreform ONE](#)’s carefully considered design allows handlers to maintain hygienic conditions and to harvest living adult specimens only.

The 144-square-foot structure comprises 224 interconnected modules set within a vault of 16 CNC-milled wood ribs. Each module consists of a 5-gallon plastic container lined with a nylon mesh sac and equipped with a ventilated door, a shading louver, and “mobility tubes” that lead to other modules. These 0.5-inch-diameter PVC tubes are lined with soft nylon mesh. Cocoon-like “sex pods” affixed to the outside of the shelter make mating a potential spectacle. Once the baby crickets, or nymphs, are strong enough, they can hop freely into the main farm via the tubes.

“This is a brilliant architectural proposition combining science, cuisine, and construction—all



executed with a sense of humor,” said juror Elizabeth Whittaker.

Crowning the shelter are 25 spiky quills, made of pipe cowls attached to 4-foot-long fins of plastic and coated masonite, that draw air and heat out via the stack effect, and amplify the sound of the crickets’ chirping. Sculpturally, the quills nod to Constantin Brâncuși’s *Bird in Space* and John Hejduk’s *The House of the Suicide*, and reflect the designer’s desire to “do something fabulous,” Joachim says.

Details like these led Whittaker to call the project “a combination of the elegant and the grotesque.” Juror Doug Stockman added, “It sort of reminds me of the scene in *The Martian* (2015) when he’s trying to grow the potatoes.”

The shelter and farm will be exhibited at the Appleton Museum of Art in Ocala, Fla., from Sept. 10 to Nov. 13. The first harvest, overseen by Robyn Shapiro of Seek Food, was used to make an infused vodka. Next on the menu? Cricket-flour bonbons with fruit and nuts. —G.s.

Module Diagram

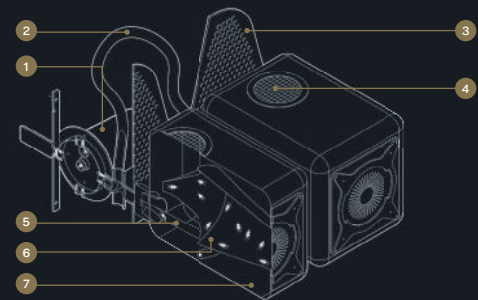

- |                     |                          |
|---------------------|--------------------------|
| 1. Sex pod          | 5. Nylon mesh tube       |
| 2. Mobility tube    | 6. Semi-rigid weave sack |
| 3. Shading louver   | 7. 5-gallon module       |
| 4. Ventilation mesh |                          |

# WINNER

**BayArc: A Tidal Responsive Barrier**





Rising sea levels are a worldwide problem, but for the approximately 500-mile shoreline of the San Francisco Bay, one partial solution may lie in something that is actually quite small: the 1.5-mile-wide mouth of the bay, where the Golden Gate Bridge crosses. If water could be stopped from surging through that opening, the San Francisco office of [Skidmore, Owings & Merrill](#) (SOM) reasoned, much of the Bay Area could be saved from flooding.

After analyzing tidal patterns in the bay, SOM worked with a multidisciplinary team, including marine engineers from Moffatt & Nichol, to identify specific days and times within a day when flood risks were highest. Their BayArc tidal response barrier, a tensile net structure, lies dormant on the seafloor until high tides trigger its deployment, creating a temporary, but nearly impervious, wall across the bay's mouth.

The flexible structure of cables and a waterproof membrane would unfold and rise, opening like a parachute filled by the water trying to squeeze from the ocean into the bay. Like a floating dam, its top edge would break the water surface, by approximately 1.5 meters, and keep most of the flow out. Once the surge dies down the structure would deflate, folding back onto the seafloor.

Using topographic data of the seafloor, the team developed 3D models of the bay and simulated the

water's motion to understand how the flows could be tamed, and how much water needed to be stopped to prevent flooding. They then designed the barrier's structure, which comprises the membrane of plastic or Teflon-coated recycled rubber interwoven with a crisscrossed grid of stainless steel or carbon-fiber cables, like the vascular system of a leaf. When the barrier is engaged, the cable structure would completely be in tension. Wave-powered compressed air would help deploy the barrier.

Though SOM has patented the system, the BayArc currently remains merely a concept for now. Other approaches to addressing sea-level rise in the Bay Area have been comparably scattered, focused on disparate segments of the shoreline as opposed to countering the problem head on, at the mouth of the bay. Though those community-based efforts are important for addressing local consequences, the region will soon need a more comprehensive plan, says SOM associate director Mark Schwettmann: "At some point, the magnitude of this problem will become apparent and there will be a cry for a more regional solution."

The jury was impressed by the barrier's potential. Juror Mic Patterson said the project "represents the kind of strategic design innovation we need in response to the tremendous challenges presented by the accelerating impacts of climate change. Let's build one and see how it works." —N.B.



# WINNER

The Tower at PNC Plaza





CONNIE ZHOU



When PNC Bank asked **Gensler** to build its Pittsburgh headquarters as the world's greenest high-rise, the design firm's San Francisco office surveyed the competition worldwide to assess the state of the art in high-performance design. They even visited projects in Germany, England, and Canada to see what worked. And then the firm compiled all the ideas together into the Tower at PNC Plaza, which opened last October.

A hybrid of tried-and-tested design concepts, the 33-story, LEED Platinum-certified structure relies on fresh air for passive ventilation and climate control an estimated 42 percent of the year, a feat that impressed the jury the most. Based on the thermal stack effect, the Tower at PNC's conditioning system combines a ventilated double-curtainwall façade, two vertical thermal shafts, and a solar chimney.

Fresh air enters through the building's outer façade and circulates through the interior as it is drawn into the centralized 350-square-foot, 400-foot-tall thermal shafts by the radiant heat created in a concrete

pad inside a rooftop solar greenhouse. Architecturally, the ventilation system manifests as a geometric array of thin rectangular panels that either lie flush with the building exterior or pop out to admit fresh air. Inside, the thermal shafts are inconspicuous and integrated, like the structural core of a typical high-rise.

"You see a lot of these buildings where they just slap on a double skin that acts as a buffer," said juror Mic Patterson. "This double façade is integrated totally into the whole building energy and ventilation system."

"It's putting together, in a unique configuration, things that have been done in simplified or singular forms elsewhere," says Gensler principal Ben Tranel, AIA, the project's technical director. And the combination works. "A mechanical engineer would say you need four fresh-air changes per hour in a space," Tranel says. "With this strategy, we get 12."

To develop the integrated system, the designers worked with engineers to determine whether to design the building's massing around the ventilation, or vice versa. Through concept validation in computer



Double-Curtainwall Façade Section

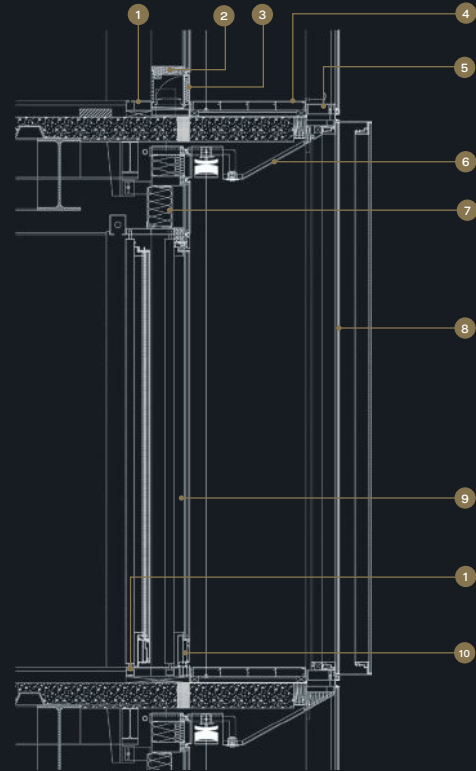

simulations and mock-ups, the team evaluated each potential approach, altering ventilation points or adjusting the depth of the cavity between the façades to attain granular detail on how the system would function. They also measured how small design adjustments would affect ventilation floor by floor, and researched what types of building automation systems and sensors could help regulate the temperature.

The final system design also includes manual controls to allow office workers to open a vent to cool a room, or close a vent to warm it as needed. Sensors feed data into dashboard displays to let occupants know when the city's air quality is high enough for the vents to be opened.

Tranel says the design team wanted the building to be “tunable,” as opposed to the countless office buildings with limited or fixed climate controls: It would be pointless to be the world's greenest high-rise if no one wanted to use it. “Human experience,” Tranel says, “is the central ingredient.” —N.B.

- |                                   |                             |
|-----------------------------------|-----------------------------|
| 1. Sliding door track             | 7. Aluminum shadow box      |
| 2. Wood mullion                   | 8. Outer vent (open beyond) |
| 3. Vent flap                      | 9. Sliding door             |
| 4. Aluminum catwalk               | 10. Extruded closure        |
| 5. Temperature sensor             |                             |
| 6. Painted aluminum closure panel |                             |

# WINNER

## LELU Exit Sign



The exit sign—humble, omnipresent, code-mandated—is begrudged by designers. Perched above doors and in the nooks of long corridors, its fluorescent letters glow, gleefully indifferent to any adjacent color palettes, finishes, and details. Though essential in emergency situations, the exit sign is often the bane of architecture practitioners.

“We thought it was an area that was ripe for design,” says Mark Wamble, a founding principal of Houston-based *Interloop—Architecture*. By stripping the sign down to its core—the four letters, E-X-I-T—he and his team have produced a sleek and elegant revision, now available commercially through Architectural Safety Components. Standard exit signs comprise illuminated metal boxes or side-lit panes of rectangular glass. Interloop found that advancements in LED technology—smaller package sizes, increased luminance, and wider cones of light—would allow the letters to stand alone without any framing or housing. With each stroke fully lit and minimally attached to the mounting armature, the letters appear to float in space.

As a life-safety device, an exit sign is subject to rigorous design standards and operational requirements for its dimensions, its light emission levels, and the strict geometries of its lettering—all of which are mandated by federal law and scrutinized by Underwriter Laboratories (UL).

Meeting these UL standards proved to be a challenge. Working with machinists, electronics manufacturers, and engineers, Interloop went through several iterations to cram enough diodes into the letter forms to achieve the requisite brightness, and to perfect the design of the acrylic and aluminum light housing. For example, the arrangement of the diodes in each colored version of the sign had to be adjusted for the different ways red light and green light disperse, and the interior surfaces of the letter lenses had to be beveled and re-beveled.

“When you make prototypes for UL, you don’t just whip something up in the back room,” Wamble says. Instead, “you engage a half dozen manufacturers and say, ‘Will you please work with us and make some

prototypes?’ and ‘This is going to take a while.’ We enjoyed it in a perverse kind of a way. It helped us clarify our ideas.”

Interloop emphasized flexibility. The design attaches the letters to the armature in multiple arrangements, enabling the sign to be mounted from any side (top, bottom, left, right). Factoring in the various add-ons like a storage case for battery backups, different arrow positions, and multiple colors, the sign can be configured in 244 ways.

Having options was important to the team, itself guilty of adding exit signs to their own drawing sets at the last minute, or at the request of a fire marshal. “Architects just ... suffer through it,” Wamble says.

The jury celebrated Interloop’s exit sign as a breakthrough for architects. “There’s going to be a widespread cheer [that] goes up in all of architecture,” juror Mic Patterson predicted.

And Interloop is eyeing other life-safety devices, such as strobe lights, fire alarms, and fire sprinklers. “All that,” Wamble says, “is ripe for rethinking.” —N.B.

# WINNER

Tally





MICHAEL MORAN/OTTO



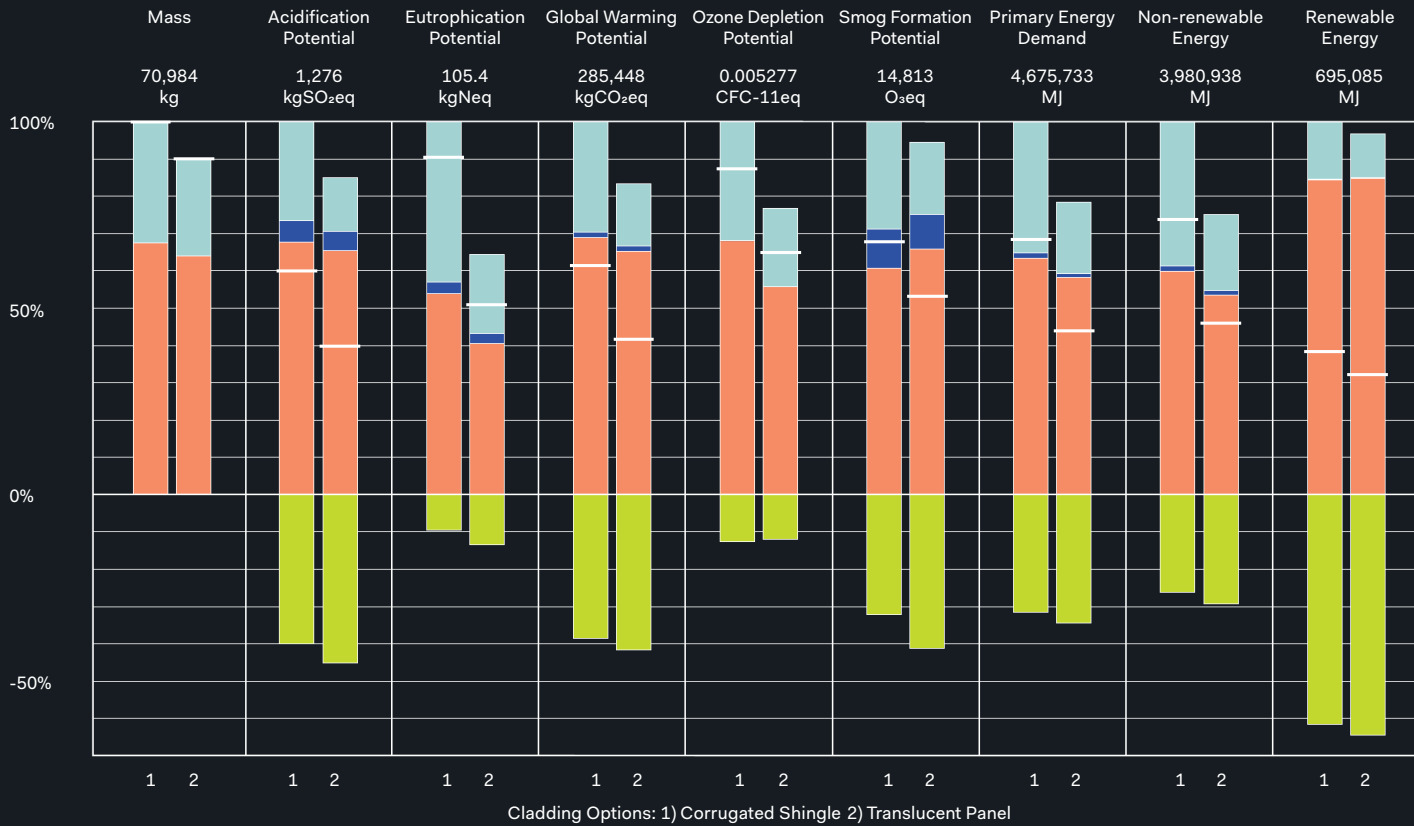

Among architects determined to minimize buildings’ environmental impact, few have had the means to quantify the energy embodied in material sourcing, processing, and construction. The prevailing system of hiring a consultant to conduct a life-cycle assessment (LCA) or cradle-to-grave analysis was “separated from design,” says Billie Faircloth, AIA, a partner at Philadelphia-based [KieranTimberlake](#).

The firm decided that architects should take the analysis into their own hands. It developed Tally, a plug-in application for Autodesk Revit that can perform an LCA on demand during the design process, when influential decisions can still be made. “This is something that badly needed to happen,” juror Mic Patterson said. “There is critical need for a simple, early-phase design tool to provide feedback related to the embodied energy impacts of material selection.”

Tally provides three types of analysis: whole building LCA, design-option comparison, and material selection. It draws upon an LCA database custom-developed by [KieranTimberlake](#) and sustainability

consultant Thinkstep (formerly PE International) that combines environmental impact data with material attributes, assembly details, and specification information. It translates building-model elements into discrete materials and quantities, and generates an inventory or “bill of materials,” which updates automatically as the design model changes. And it outputs comprehensible charts and graphics, not just spreadsheets full of numbers.

“It’s holistic in thinking,” juror Doug Stockman said. Juror Elizabeth Whittaker remarked, “You can imagine this being absolutely necessary for any kind of building design. Finally: a method of life-cycle assessment that is user-friendly.”

Architects can compare the relative environmental impact of structural systems such as concrete, steel, and timber; or evaluate comparable materials, such as two insulation types with identical R-values. Conveniently, Tally can also provide scaled results based on a portion of a model, such as a 10-foot-square section. [KieranTimberlake](#) associate and

## Life Cycle Stages

- Manufacturing
- Transportation
- Maintenance and Replacement
- End of Life

— Net value (impacts + credits)

Option 1: Corrugated Shingle Cladding



Option 2: Translucent Panel Cladding (Selected)



KieranTimberlake used Tally to compare the environmental impact of two cladding options for its design of the Consortium for Building Energy Innovation, in Philadelphia.

researcher Roderick Bates says, “You run the assessment and then extrapolate it, even without a completed full building model.”

KieranTimberlake beta-tested the software with 400 architects, engineers, academics, and students before introducing Tally at Greenbuild 2013. “Our goal was to use the BIM platform to harness the information that is already nestled within these models and the knowledge within the team,” says KieranTimberlake associate and researcher Stephanie Carlisle.

Now commercially available through the Autodesk app store and KieranTimberlake’s affiliate company, KT Innovations, Tally was used by hundreds of firms and more than 50 academic institutions in the last year. The latest version, Tally 2017, contains updated graphics and enhanced capacity to interface with evolving material information, standards, and software. Faircloth says users can expect increasing specificity in the program’s output as more manufacturers file Environmental Product Declarations. Tally, Bates says, “is like a building that you never stop building.” —c.s.

# CITATION

**Pulled Plaster Panels**



Traditional Technique

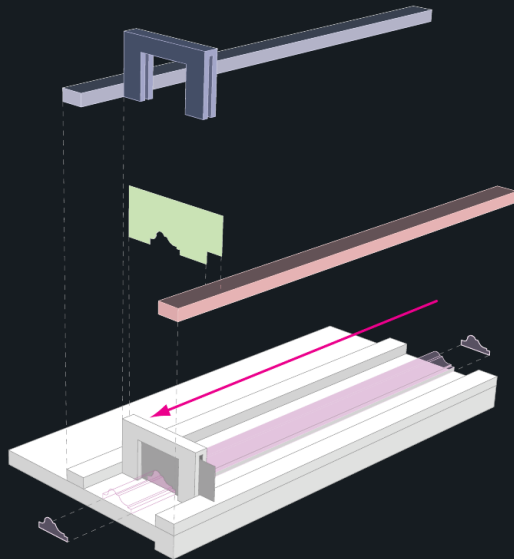

Modified Technique

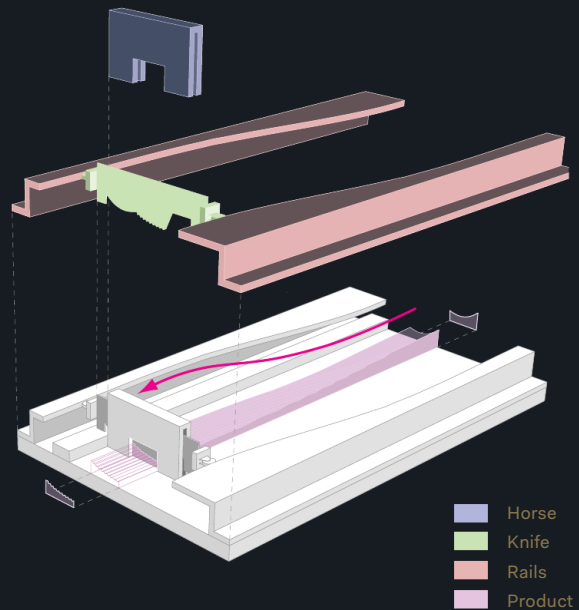

To create a custom tiled surface that wraps a 1,000-square-foot core wall of a New York duplex apartment, Bryan Young, AIA, considered using felt, glass, and metal. Then he came upon plaster. Plaster is both economical and full of “rich and unexplored” potential, he says. His curiosity was piqued when an artisan introduced him to the time-honored technique of pulled plaster, in which a pile of wet plaster is scoured into shape by a contoured die (“knife”) and carrier (“horse”) pulled along straight rails. The technique is used to make crown molding.

But Young imagined using the process in a radically different way: to create plaster panels that are mounted vertically, with joints obscured to form a “sculpted monolith.” Rather than the straight and uniform extrusion of crown molding, he and his Brooklyn-based firm, *Young Projects*, designed wavelike “sweep” profiles through a combination of 3D modeling software and physical modeling.

They settled upon six master panel templates—each 7 feet long by 6 inches wide and between 0.375 inch and 3 inches deep—that give the impression of endless variation when arranged in different sequences. The panels could also be sliced in half to add further unpredictability in the overall installation pattern. The seamless appearance of the wall results not only from

the scalloped surface geometry of the panels, but also because the pointing material, gypsum plaster, blends chemically and thermally with the plaster panels.

While others might have turned to CNC milling to execute the irregular panels, Young was determined to work manually with the wet plaster. But all the tools had to be modified: the knife required new profiles, the horse needed to allow the knife to slide side to side and up and down while being pulled forward, and the rails had to be cut and sanded to define a smooth arc.

“I appreciated the tactile quality of the panels, and especially in the process of making them,” said juror Doug Stockman. Juror Elizabeth Whittaker called the ribbed panels “quite beautiful,” adding: “It is exciting to see a product that allows for the customization and possibilities of the extruded fabrication process.” And juror Mic Patterson commended “the nuanced complexity of form yielding from this novel yet simple craft technique.”

Ultimately, the 674 installed wall panels were cast in molds derived from the six original hand-pulled masters. Casting results in a more durable product, Young says, and these full-height panels are likely to be bumped and touched as crown moldings are not. Still, he says, “the design of the apparatus and technique of pulled plaster are embedded within the product.” —G.S.

# CITATION

Chicago Horizon





This open timber pavilion with an overhanging roof was named the winning design of the Lakefront Kiosk Competition in 2015. Completed last October in Grant Park for the Chicago Architecture Biennial, Chicago Horizon has a square, flat canopy measuring 56 feet on each side—the maximum length of timber that can be legally carried by a truck.

The roof is the first point-supported, two-way slab structure to be built with timber, according to the design team members, *Ultramoderne* co-principals Aaron Forrest, AIA, and Yasmin Vobis, who are based in Providence, R.I., and structural engineer Brett Schneider, a senior associate at *Guy Nordenson and Associates* in New York.

The canopy consists of two plies of cross-laminated timber (CLT) panels laid crosswise to each other. The 14 panels, each 8 feet wide and 4.125 inches thick, are topped by a rubber waterproofing membrane and gravel ballast. Overall, the roof weighs around 135,000 pounds, nearly half of which is the CLT itself. The load of the roof slab is carried in perpendicular directions and bears directly on 13 glulam columns distributed in a radial pattern, as opposed to the typical beam-and-column grid. “The builders said, ‘Why didn’t you just do a frame?’” Schneider says. “We see two-way slabs in concrete everywhere, but in timber it’s very unusual.”

“They’re leveraging this material to its fullest potential,” juror Doug Stockman said, “and then creating the forms, the space, and the shapes out of that.” Juror Elizabeth Whittaker added, “This project masters an economy of means and material that is precisely and exquisitely detailed.”

The crucial pavilion details, according to the designers, are the column-to-ground connections, column-to-roof connections, roof perimeter, viewing aperture edges, and the chain link surrounding the stairs and kiosk. The team specified the configuration and angles of fasteners to maximize the roof span and to resist the shear forces of winds from Lake Michigan.

Visual intrigue was as much of a goal as technical prowess. Visitors can poke their heads through a portal in the roof by climbing the freestanding dual staircase-and-seating area, which terminates in a landing beneath the roof level. “When you go up the stairs, the roof becomes a plane to frame your vision of the horizon and the city,” Vobis says. On grade, the long side of each rectangular column is rotated to point in a different direction, guiding visitors’ gaze into the heart of the pavilion and back out to the horizon.

Juror Mic Patterson said, “This is a classic minimalist construction. The more you contemplate it, the more its subtle sensibilities draw you in.” —G.S.

# CITATION

Spray-On House





Polyurethane spray foam is known for its use as insulation, quickly and effectively filling in wall cavities and lining attic roofs. The Spray-On House by Patrick Tighe Architecture shows how it can do much more.

After years of researching the high-density spray foam's structural capability, the firm is embarking on its first building using the material. The single-family house in the quirky and remote desert community of Pioneertown, Calif., will be a curvaceous, gourd-like mound with globular interior spaces and hardly a straight line to be found. The spray foam, installed in one continuous application, in combination with a cage of steel reinforcing bars, will become the house's foundation, walls, and roof.

Polyurethane is an ideal construction material for the remote site, where access would be all but impossible for multiple trades and their equipment. Requiring minimal materials and labor, the house is expected to cost just \$125 per square foot. And by using soy-based foams, the environmental impact of building the Spray-On House will be significantly less than a comparable house built in concrete. A life-cycle assessment of the prototype house found that it would require less than half of the fossil fuels consumed in concrete construction and produce about 10 percent of the harmful respiratory inorganic compounds.

The firm's past research into spray foam culminated in a 2011 temporary installation (shown at left) at the Southern California Institute of Architecture that used a combination of high- and low-density foams to build a free-standing, parabolic chamber. "We were looking at the thinnest shell we could get, using the highest density foam," says firm principal and lead designer Patrick Tighe, FAIA. The prototype shell was 3 inches thick, stood 20 feet tall, and covered 600 square feet.

The 2,700-square-foot Spray-On House will require greater foam thicknesses, ranging from a few inches at the roof to a few feet at the wall base. The project's engineers have tweaked details like the location and size of interior walls to ensure the structure can support itself. In addition, the team has built full-scale prototypes of wall sections and footings to optimize the quantity and thickness of the foam.

The firm is still determining how best to coat and waterproof the house exterior. Still, Tighe says, the biggest challenge has been navigating the project through the building code.

Bureaucracy aside, the jury saw great potential in this exploration of foam-based design and construction. "It seems unlimited in what you can do with the process," juror Elizabeth Whittaker said. —N.B.



# CITATION

Vegas Altas Congress Center





The architects behind the new Vegas Altas Congress Center in Villanueva de la Serena, Spain, wanted the 74,000-square-foot project to blend seamlessly into the landscape, becoming a scenic fringe between the medieval town's urban streetscape and its agricultural hinterlands. But they also wanted the building to be a landmark, distinct from its bucolic setting. So they crafted a structure that does both.

The four-person design team—Luis Pancorbo, José de Villar, Carlos Chacón, and Inés Martín Robles—partly buried the center's two large auditoriums before topping them with an expansive public plaza. Bursting from this flat surrounds is their counterpoint: a bold, cubic building cast in place with gold-colored concrete and punctuated with geometric window and skylight cutouts. To soften the contrast, the designers wrapped this cube, which houses a restaurant, offices, and service space, in a veil of horizontal bands that follow the cube's rounded corners, orbiting the structure in regimented paths inspired by the lines cut into farm fields after harvest. The veil also obscures the underlying concrete form from a distance, while providing invaluable shade to building occupants during the region's hot summers.

For the veil, the designers initially planned to use straight lengths of plastic pipe, but the cost was too

high. In their hunt for an alternative, they discovered what turned out to be a superior material: naval-grade rope made from recycled plastic. Not only did the rope cost less, but the designers could customize its colors to include a mix of yellows, oranges, and greens, mirroring the surrounding fields and imbuing the building with the likeness of a hay bale.

Though the design clearly specified the ropes' thickness and spacing, along with the cantilevered, painted-steel armature that would support them, their precise attachment method remained uncertain until the center was nearly complete. As construction was wrapping up, the architects and their engineers rapidly explored different techniques to secure the ropes to the armature, "testing and trying again, and testing and trying again," Pancorbo says.

Finally, the team identified that 12-centimeter-diameter rebar would support the ropes, and that 10 or 11 brackets per elevation would ensure the ropes stayed horizontal and taut around the building. The rebar is painted to match the rope, to minimize its appearance.

The jurors praised the Vegas Altas as a monumental artifact. Juror Doug Stockman was particularly taken by the veil, both for its outward appearance and for the "effect it has, especially in that interstitial space" between rope and concrete. —N.B.

# CITATION

Nanobiome Building Skin



## Analysis and Components Diagram

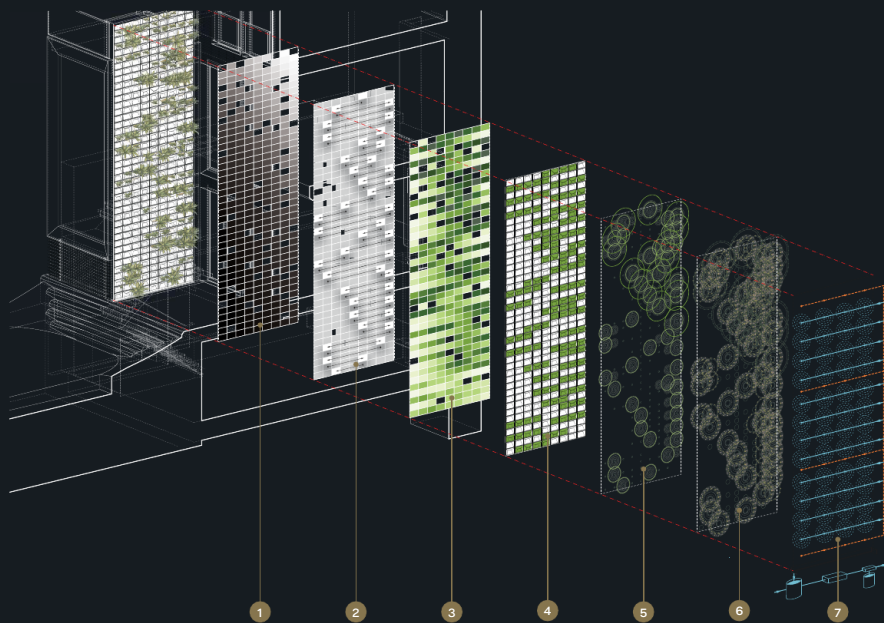

1. Annual direct-sunlight exposure, from 111 hours (black) to 296 hours (white)
2. Shadow avoidance
3. Unique molds
4. Soil volume distribution
5. Winter plant spread
6. Summer plant spread
7. Aeroponic irrigation system

Though green walls sound nice in theory, they can be a mess in practice. The mounting armatures often are complicated and costly to build; vertical irrigation easily becomes uncalibrated; and plants receiving uneven water levels or sun exposure quickly die out.

For the Nanobiome Building Skin, a green wall for a Manhattan apartment, local firm **Michael K Chen Architecture** (MKCA) tackled these issues by using data and modeling to specify everything from the plant species and their arrangement to the manufacture of their containers. The result is a green wall perfectly tuned to its surroundings and ecosystem.

MKCA began by mapping the project site's environmental conditions to identify not just which plants to select but also which biome the green wall would be mimicking. Working alongside designers from Brooklyn, N.Y.-based Local Office Landscape Architecture and conservation biologists at the State University of New York College of Environmental Science and Forestry, in Syracuse, MKCA pinpointed the site's natural analog to the limestone cliffs of the Hudson Valley.

In Grasshopper, MKCA modeled the apartment's wall with a grid based on its varied exposure to sunlight and shade. It then used a genetic algorithm to optimize the location of each species of fern,

wildflower, and moss, and how their fitness would range over the course of the year under different conditions.

The grid also influenced the shape and structure of the custom terra-cotta tiles and 10 different types of container modules in the façade. Ranging from flat panels to shallow planters, and from deep planters to wedges, the terra-cotta forms respond directly to the environmental conditions and needs of each plant in each location and, in some areas, even create shade to help the plants below thrive.

Completed this June, the wall is also an exercise in conservation. It hosts three variations of an endangered fern species, which botanists will be periodically checking to gauge which may be a good candidate for broader propagation and perhaps even commercialization. "We're trying to find ways for the act of conservation to become more integral to the aesthetics of the building and the façade," says MKCA principal Michael Chen, AIA.

The jury praised the Nanobiome Skin for combining computational design with the comparably low-tech process of terra-cotta manufacturing, and for its potential contribution to urban ecology. "I love the idea of the façade creating a microclimate in a city," says juror Elizabeth Whittaker. —N.B.

# HONORABLE MENTION

## Infundibuliforms: Kinetic Tensile Surface Environments

A metal ring woven with mesh, like a giant embroidery hoop, suspends from the ceiling. Suddenly, the netting moves and breaks the plane of the ring in opposing directions, creating three convex or concave funnels. Within seconds, the infundibuliform (meaning funnel- or cone-like) shapes shift again, collapsing into themselves, transitioning from mountain peaks to vortices and back again.

This exploration of kinetic architecture is the culmination of years of research and development in digital modeling, fabrication, and robotics by Kathy Velikov, AIA, and Geoffrey Thün, directors of Ann Arbor, Mich.-based RVTR, in collaboration with fellow University of Michigan faculty member Wes McGee, a principal and co-founder of Boston-based Matter Design. Computational design tools have made kinetic architecture increasingly attainable in theory, but translating digital simulations into physical objects has remained a stumbling point. Using Rhino, Grasshopper, and Kangaroo, the team created a design program that simulates what shapes and movements are possible given the constraints of physics and space, and tested applied forces on an extruded-elastomeric mesh. “It allows designers a one-to-one and immediate way to visualize something that’s very complex,” Velikov says.

Data gathered by the simulations guided the unique geometry of a mesh pattern that would enable the form to lie flat, stretch up, or distend down. Using a custom-built extruder, the team 3D printed flat panels of the tensile net surface with the thermoplastic elastomer. The physical net mimics the behavior simulated in the digital model spot-on.

Kinetic forms can be used to tune rooms acoustically or to alter the geometry of an enclosure for different lighting conditions. The team’s digital modeling and physical fabrication process is an “ingenious new technique,” juror Elizabeth Whittaker says. “The formal possibilities seem endless.” —N.B.

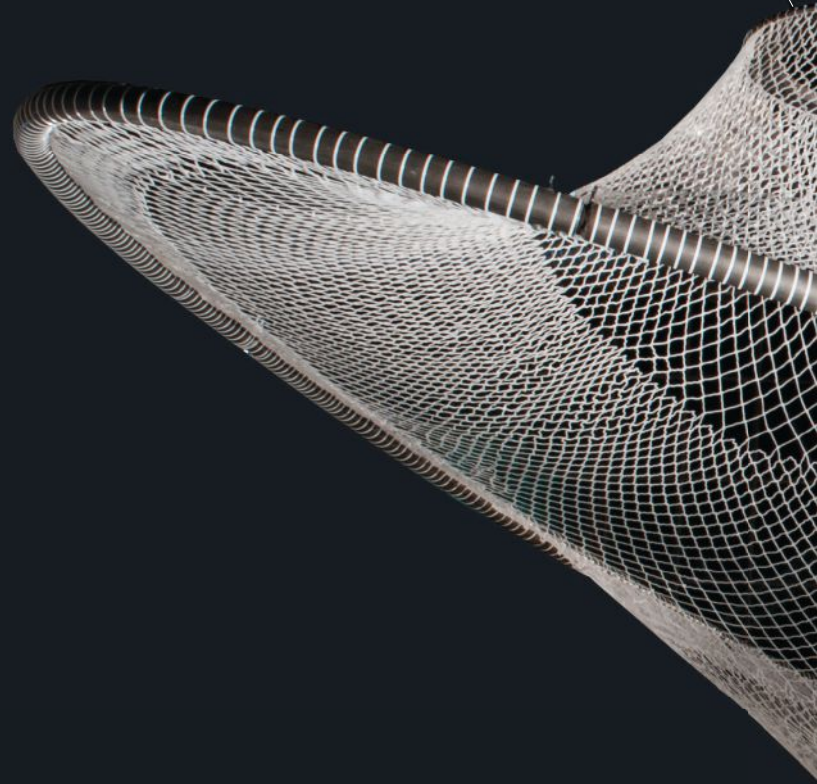

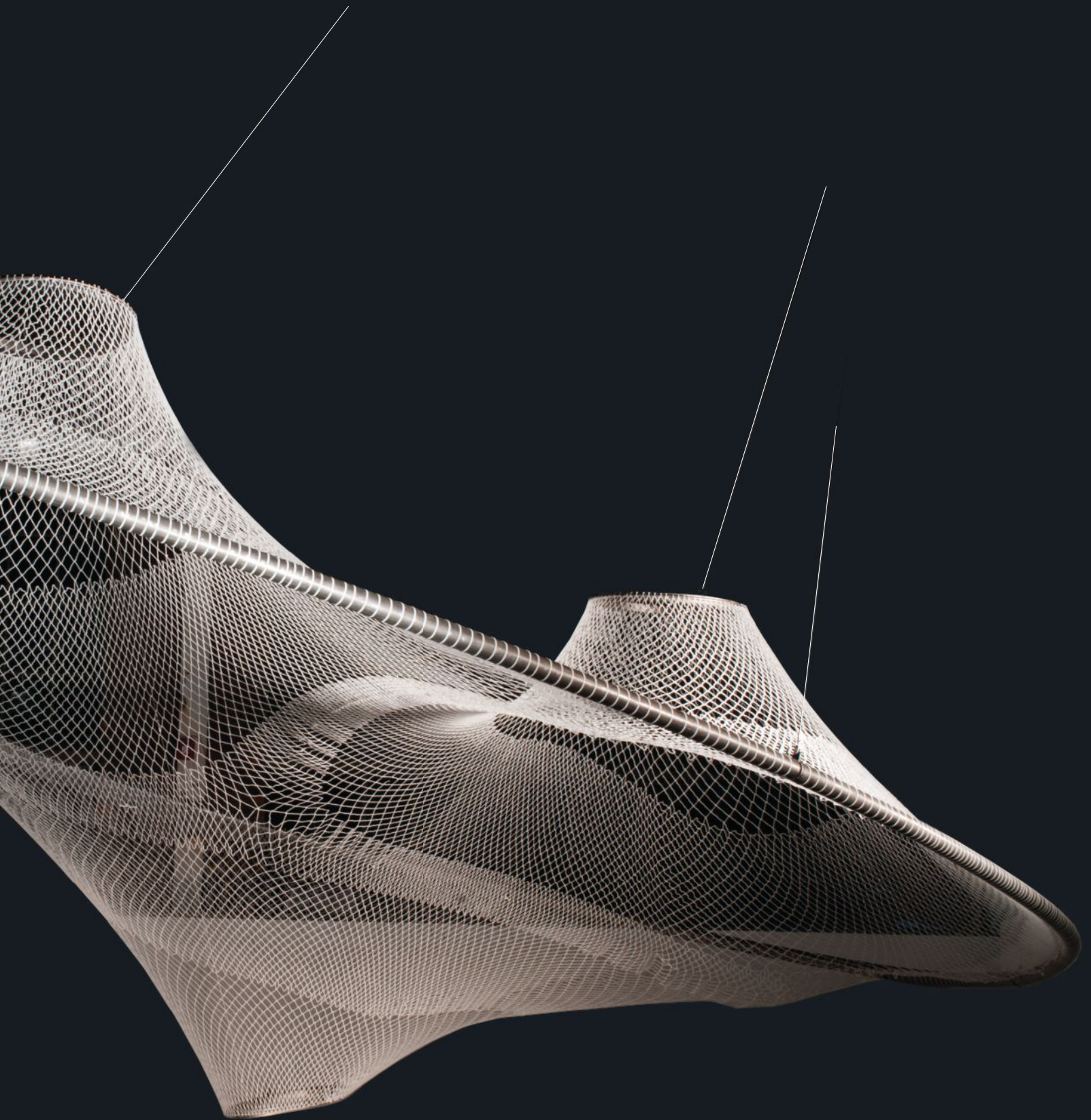

# HONORABLE MENTIONS

## Timber Waste Modular Unit



Wood products are enjoying a renaissance in architecture. But when designers Yugon Kim and Tomomi Itakura, partners at Boston-based IKD, looked at the life cycle of timber, they found “inefficiencies in maximizing carbon sequestration, one of which was the unused waste from the milling process,” Kim says. They wanted to reuse the C-shaped trim pieces of logs—which can comprise up to 38 percent of a felled tree—without down-cycling them into lower-grade products like particleboard, wood pulp, mulch, or fuel.

Their solution is remarkably simple: turn the pieces’ flat, sawn faces out and create blocks that can stack in modular fashion. Kim, a former sculptor and furniture designer, and Itakura salvage the edges from local sawmills, cut them into manageable 8-inch lengths, and reassemble them four pieces a time, with mitered corners. The resulting “Timber waste Modular Unit” (“TwMU”) is a hollow, load-bearing block. Juror Doug Stockman contrasted the elegance

of IKD’s prototype, in which “literally the edges are ripped off and reassembled in a different way, without further manipulation,” to other wood products that use reconstituted material.

For the first trial of the TwMU system, IKD built a five-course-tall circular bench around the base of a tulip tree at the Heritage Museums and Gardens in Sandwich, Mass. During its five-month tenure, the blocks began to crack, Kim says, due to the uneven release and absorption of moisture. IKD began developing new prototypes to improve TwMU’s durability. They drilled notches to facilitate evaporation and contraction, and applied coatings of beeswax, pine tar, and char. They also tested hardwood versus softwood, and green versus kiln-dried wood. As of press time, these second-generation prototypes had endured nine months outdoors, with the notched and coated versions faring better than the initial prototypes. Kim plans to run the trial for two years. —G.S.

## Grove



At the 2015 Design Biennial Boston, a cluster of curious, oblong vessels propped on a metal armature invited onlookers to pop their heads into an enclosure created by the intersecting volumes of their papier-mâché-like skins. The cluster of 8- to 10-foot-tall, 4-foot-diameter forms is titled *Grove*. Brookline, Mass.-based **GLD Architecture** designed the installation to give people the experience of simultaneously inhabiting an intimate enclosure and a public space.

*Grove* represents a significant advancement in architectural form-making. By combining composite-based structural analysis with inflatable vinyl forms, GLD has developed a workflow that embeds structural logic into design from the very start—and at a low cost.

Principal Joel Lamere says the pillow-like forms are designed materially, as opposed to identifying the appropriate construction materials after design is completed. The team used Grasshopper, the physics engine Kangaroo, and the structural analysis

program Karamba to simulate how *Grove*'s forms would appear when inflated, which directly guided its fabrication. Patterns of vinyl sail material were cut and sewn into balloons that were inflated to act as the molds. These bulbous forms were then covered with layers of fiberglass strips and coated with resin. After an approximately 24-hour cure, the vinyl balloons were deflated and removed from the now-rigid fiberglass structures.

The digital simulation tools also informed the configuration of the 12 intersecting vessels, optimizing *Grove*'s overall stability. Just 2 millimeters thick, the curvaceous shells are incredibly sturdy. "It's cladding and structure in a single surface," Lamere says. GLD has used a similar molding process to create furniture.

The jury selected *Grove* as much for its intriguing design as for the ideas behind it. "The intelligence of this fabrication process results in a highly sophisticated, formal ensemble," says juror Elizabeth Whittaker. —N.B.



# HONORABLE MENTION

## Blooming Bamboo House



Vietnam suffers from a relentless cycle of floods, landslides, earthquakes, and more. Because much of the country's housing stock is poorly constructed—and unsanctioned—the natural disasters destroy thousands of families' homes every year.

To minimize the risk of destruction, Hanoi-based **H&P Architects** developed the Blooming Bamboo House, a residential housing model that utilizes local materials and can be built by laypeople at a low cost.

The 62-square-meter (670-square-foot) prototype is the first structure in Vietnam to be built almost entirely out of bamboo, according to H&P principal Doan Thanh Ha. The material's high tensile strength enables the house to withstand strong winds and earthquakes, while a foundation of salvaged plastic drums will allow it to endure floods of up to 1.5 meters (4.9 feet).

Bamboo poles ranging in diameter from 8 to 10 centimeters are tied or bolted together to create the

building frame, followed by smaller lengths that are tied onto the walls or lined on the floors as finishes, and sealed with bitumen to prevent water infiltration. The house can also be finished with other local materials, such as wooden planks, coconut leaves, plastic sheets, and bottles.

With an open floor plan and simple structural system, the house is designed to be built in modules of square rooms quickly and inexpensively; the prototype was built in just 25 days for \$2,500, and accommodates six residents. Owners can adapt and expand their homes to include porches and veranda windows. Along with its storm resistance, the house's cubic shape and pitched roof establish an eye-catching vernacular that alludes to the traditional homes of the region.

Juror Mic Patterson called the house "a reminder of what can be realized with indigenous materials and building practices sensitively handled." —N.B.

## Jury

**Mic Patterson** is founding principal of Los Angeles–based Design Tectonics, a consultancy that focuses on innovative façade technology applications and research. He was formerly the vice president of strategic development at Enclos. Patterson is a Ph.D. candidate in the University of Southern California School of Architecture with a focus on sustainable façade renovation practices.

**Douglas Stockman**, AIA, is a founding principal at El Dorado in Kansas City, Mo. He also serves on the Kansas State University College of Architecture, Planning, and Design Dean's Advisory Council, and is chair of the Downtown Council of Kansas City. Stockman received a B.Arch. from Kansas State University.

**Elizabeth Whittaker**, AIA, is founder and principal of Merge Architects in Boston. In 2015, she was a recipient of the AIA Young Architects Award and the Emerging Voices award from the Architectural League of New York. Whittaker received an M.Arch. from the Harvard Graduate School of Design, where she is an assistant professor in the practice of architecture.

## Credits

### **Cricket Shelter: Modular Edible**

#### **Insect Farm, page 112**

*Client:* Randy Jayne Rosenberg  
*Design Firm:* Terreform ONE, Brooklyn, N.Y. · Mitchell Joachim, ASSOC. AIA, (co-founder and primary investigator); Jiachen Xu, Lissette Olivares, Cheto Castellano, Ivan Fuentealba, Sung Moon, Kamila Varela, Yucel Guven, Chloe Byrne, Miguel Lantigua-Inoa, AIA, Alex Colard, Melanie Fessel, Maria Aiolova, ASSOC. AIA, Vivian Kuan (project management); Felipe Molina, Matthew Tarpley (research assistants)  
*Consultant:* Seek Food · Robyn Shapiro  
*Fabricators:* Shandor Hassan, Christian Hamrick  
*Funding:* Art Works for Change; Terreform ONE  
*Photography:* Mitchell Joachim, Matthew Tarpley  
*Special Thanks:* David Stewart, Christian Hubert, Heather Lord, Scott Pobiner, New Lab, Brooklyn Navy Yard, GMD Shipyard, New York University Gallatin School of Individualized Study

### **BayArc: A Tidal Responsive Barrier, page 116**

*Design Firm:* Skidmore, Owings & Merrill, San Francisco · Craig Hartman, FAIA (concept and interdisciplinary leader); Mark Schwettmann, AIA, Alex Cruz, Ross Findly, David Kwon (project team)  
*Project Adviser:* Moffatt & Nichol  
*Drawings:* Skidmore, Owings & Merrill  
*Structural Engineer:* Mark Sarkisian, Eric Long, David Shook, Geoffrey Brunn  
*Marine Engineering Concept:* Moffatt & Nichol · Dilip Trivedi, Richard Dornhelm

### **The Tower at PNC Plaza, page 118**

*Client:* PNC Financial Services Group  
*Design Firm:* Gensler, San Francisco · Doug Gensler, AIA (principal-in-charge); Hao Ko, AIA (principal and architectural design director); Benedict Tranel, AIA (principal and technical director); Lisa Adkins, AIA (project manager); Anastasia Huggins, AIA, David Hall, Gunwook Nam, Alison Wilkinson, AIA, Daniel Nauman, AIA, Jorge Barrero, AIA, Ethel Macleod, Eugene Lee, Joe Chisholm,

Brent Van Gunten, AIA, Len Sciarra, Philip Kaefer, AIA, Joel McCullough, AIA, Rich Peake, Mariana Vaida, Jessica Yin, Yooju No (project team)  
*Rendering:* Space Matrix; Tangram 3DS  
*Construction Manager:* PJ Dick  
*Lighting Designer:* Fisher Marantz Stone  
*Structural and M/E/P Engineer:* BuroHappold  
*Sustainability Consultant:* Paladino & Co.  
*Photography:* Connie Zhou Photography

### **LELU Exit Sign, page 122**

*Client:* Architectural Safety Components  
*Design Firm:* Interloop—Architecture, Houston · Mark Wamble, Dawn Finley, AIA (design principals); Eric Hughes, Peter Muessig, Jack Mussett (project team)  
*Project Adviser:* Architectural Safety Components · Sam Youdal  
*Consultant:* Martin Co. · John Martin  
*Fabricators:* Moore Fabrication · Kerry Krumbek; Professionalized Products and Services · Jerry Huang; Southwest Electronic Energy Group · Alex Marin; Anodizing Graphics of Houston · Linda Sayers  
*Special Thanks:* Underwriters Laboratories · Abdul Ahad (investigating engineer)

### **Tally, page 124**

*Design Firm:* KieranTimberlake, Philadelphia · Roderick Bates, Stephanie Carlisle, Billie Faircloth, AIA, Elizabeth Friedlander, AIA, Ryan Welch (project team)  
*Development Partners:* Autodesk; Thinkstep (previously PE International)  
*Project Team:* Autodesk · Jonathan Rowe; Thinkstep · Heather Gaddoniex, Nick Santero, Maggie Wildnauer  
*Special Thanks:* Emma Stewart, Jacky Liang

### **Pulled Plaster Panels, page 128**

*Design Firm:* Young Projects, New York · Bryan Young, AIA (principal); Jon Cielo, AIA (project architect); Noah Marciniak, Samantha Eby, Nayoung Kim (project team)  
*Lighting Designer:* Architectural Lighting · Rick Shaver  
*Structural Engineer:* Silman · Nat Oppenheimer

*Electrical Engineer:* Engineering Solutions · John Ryan  
*Consultants:* Butter and Eggs · Judy Dunne (interiors); Taocon (general contractor); Engineering Solutions · John Ryan (M/E/P engineering)  
*Drawings:* Young Projects  
*Fabricators:* Kammetal (stainless steel screen); Balmer Architectural Mouldings  
*Photography:* Young Projects and Jon Cielo

### **Chicago Horizon, page 130**

*Client:* Chicago Architecture Biennial, Chicago Park District  
*Design Firm:* Ultramoderne, Providence, R.I. · Yasmin Vobis, Aaron Forrest, AIA, Emily Yen, ASSOC. AIA, Tida Osotsapa, Will Gant, Hua Gao, Ronak Hingarh (project team)  
*Design Structural Engineer:* Guy Nordenson and Associates · Brett Schneider  
*Structural Engineer of Record:* Thornton Tomasetti  
*Architect of Record:* Animate Architecture · Joe Lambke  
*Fabricator:* Nordic Structures  
*Funding:* BP; Chicago Park District; Chicago Architecture Biennial; Rhode Island School of Design; ReThink Wood; Nordic Structures  
*Photography:* Naho Kubota  
*Special Thanks:* Laura Briggs

### **Spray-On House, page 132**

*Design Firm:* Patrick Tighe Architecture, Los Angeles · Patrick Tighe, FAIA, Zachary Teixeria, Evelina Sausina, ASSOC. AIA, Risa Tsutsumi, Bran Arifin (project team)  
*Structural Engineer:* Nous Engineering · Matt Melnyk  
*Consultant:* Demilec  
*Fabricator:* Machineous  
*Life-Cycle Assessment:* Department of Civil and Environmental Engineering, School of Engineering, Stanford University  
*Prototype:* Built at Southern California Institute of Architecture (SCI-Arc), as part of the SCI-Arc Gallery Series  
*Drawings, Renderings, and Photography:* Courtesy Patrick Tighe Architecture  
*Special Thanks:* SCI-Arc team

**Vegas Altas Congress Center and Auditorium, page 134**

*Client:* Junta de Extremadura  
*Design Firm:* Pancorbo + de Villar + Chacón + Martín Robles, Madrid · Luis Pancorbo, José de Villar, Carlos Chacón, Inés Martín Robles (project team)  
*Drawings and Lighting Designer:* Luis Pancorbo, José de Villar, Carlos Chacón, Inés Martín Robles  
*Structural Engineer:* Mecanismo · Juan Rey, Pablo Vegas, Jacinto Ruiz Carmona  
*Electrical and Facilities Engineering:* Úrculo Ingenieros · Rafael Úrculo, Sergio Rodríguez  
*Acoustics:* Arau Acústica · Higiní Arau  
*Models:* Gilberto Ruiz  
*Construction:* Placonsa · Eloy Montero; Julio Oreja (site manager)  
*Ropes Installation:* Cotesi; Lastra & Zorrilla  
*Funding:* Junta de Extremadura  
*Cost:* €10,505,187 (\$11.7 million, approx.)  
*Photography:* Jesús Granada (building); Ignacio Bisbal Grandal (model)

**Nanobiome Building Skin, page 136**

*Design Firm:* Michael K Chen Architecture (MKCA), New York · Michael Chen, Justin Snider, AIA, Alan Tansey, Natasha Harper, Elena Hasbun, Braden Caldwell, AIA, Julian Anderson, AIA (project team)  
*Drawings:* MKCA  
*Landscape Architect:* Local Office Landscape Architecture · Walter Meyer, Jennifer Bolstad, AIA, Jenny Hindelang  
*Conservation Consultant:* State University of New York College of Environmental Science and Forestry, Department of Environmental and Forest Biology · Danilo Fernando (associate professor and graduate program director)  
*Façade and Structural Engineer:* Buro Happold  
*General Contractor:* IA Construction Management  
*Manufacturer:* Boston Valley Terra Cotta  
*Photography:* MKCA

**Infundibuliforms: Kinetic Tensile Surface Environments, page 138**

*Design Firms:* Matter Design, Boston · RVTR, Ann Arbor, Mich., and Toronto · University of Michigan  
*Primary Investigators:* Wes McGee, Geoffrey Thün, Kathy Velikov  
*Design Research Associate:* Daniel Tish  
*Fabrication Assistants:* Asa Peller, Dustin Brugman, Andrew Kremers, Andrew Wald, Iram Moreno Pinon  
*Wireless Sensing Adviser:* Jerome Lynch  
*Technical Partners:* Buckeye Polymers; Industrial Fabricating Systems; Beckhoff  
*Funding:* Taubman College of Architecture and Urban Planning; 2016 Research Through Making Program; University of Michigan Office of Research; Small Projects Grant  
*Photography:* Peter Smith

**Timber Waste Modular Unit ("TwMU"), page 140**

*Design Firm and Fabricator:* IKD, Boston · Yugon Kim, Tomomi Itakura (leaders); Yuki Kawae, Steven Hien, Brendan Casimir, David Morgan, Erin Kim, James Fan, Miguel Lorenzo Gumila (student research assistants)  
*Drawings:* IKD  
*Funding:* Heritage Museums & Gardens; Rhode Island School of Design  
*Photography:* IKD  
*Special Thanks:* Windy Hill Farm Sawmill

**Grove, page 141**

*Client:* Design Biennial Boston, Boston Society of Architects (BSA)  
*Design Firm and Fabricator:* GLD Architecture, Brookline, Mass. · Joel Lamere, Cynthia Gunadi, Sophia Chesrow, Grigori Enikolopov, Zain Karsan, Dohyun Lee, Elizabeth Galvez (project team)  
*Drawings:* GLD  
*Funding:* Design Biennial Boston; GLD  
*Photography:* Jane Messinger  
*Special Thanks:* Rose F. Kennedy Greenway Conservancy, Boston Art Commission, Pinkcomma Gallery, BSA Space, Boston Mayor's Office of New Urban Mechanics, David Costanza, Sixto Cordero, Caitlin Mueller, Steven O. Anderson, John Skibo, Matt Wagers, Chris Dewart, Christopher Gunadi

**Blooming Bamboo Home, page 142**

*Design Firm:* H&P Architects, Hanoi, Vietnam · Doan Thanh Ha, Tran Ngoc Phuong, Chu Kim Thinh, Erimescu Patricia, Nguyen Van Manh, Nguyen Khanh Hoa, Nguyen Quynh Trang, Tran Quoc Thang, Pham Hong Son, Hoang Dinh Toan, Pham Quang Thang, Nguyen Hai Hue, Nguyen Khac Phuoc (project team)  
*Fabricator:* H&P Architects  
*Photography:* Doan Thanh Ha  
*Cost:* \$2,500  
*Special Thanks:* Nguyen Tri Thanh