

# MAKING BUILDINGS MOVE

*Advances in mechanization and power electronics have helped to make retractable roofs and large operable walls and doors more practical and efficient to build. In recent years, architects and engineers have collaborated to develop new, creative forms of kinetic architecture. Three recent projects incorporating large kinetic elements highlight the critical roles played by structural engineers in integrating structural designs with the mechanization elements needed to make structures move.*

.....  
**By Brian Hamill, P.E., M.ASCE**

**K**INETIC ELEMENTS in architecture have existed for a long time. In its most basic form, a window or a door can be considered a kinetic element. In recent years, however, architects have incorporated much more elaborate kinetic elements into their building designs. The inclusion of kinetic elements can add versatility and a unique character not easily attained otherwise.

The harnessing of electricity led to a major leap forward in such designs. Electric motors spawned a host of new kinetic elements, for example, the modern versions of elevators and escalators. On a larger scale, electric motors coupled to such mechanical elements as gears and shafts made possible the proliferation of larger-scale kinetic architecture, including movable bridges. During the past two or three decades, nonindustrial buildings have to an increasing extent been outfitted with such large-scale kinetic elements as retractable roofs and large operable walls or doors. In some cases, even entire buildings can be made to move to enclose an outside space, transforming that exterior area into an interior space and facilitating a much wider range of uses.

Hardesty & Hanover (H&H), of New York City,

© ALAN KARCHER FOR SANTIAGO CALATRAVA LL (ALL RIGHTS RESERVED)



To shade its expansive glass facade, the Innovation, Science and Technology Building, located in Lakeland, Florida, on the campus of Florida Polytechnic University and designed by Santiago Calatrava, includes an operable brise-soleil, or large sunscreen. Over the course of the day, the brise-soleil moves in line with the sun's path through the sky.



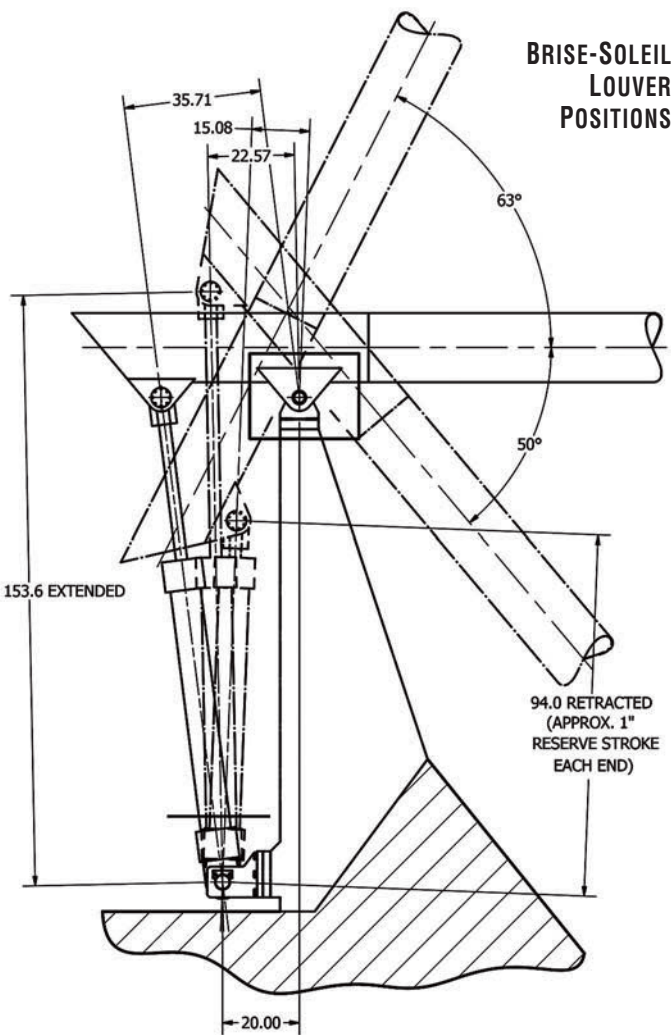

A series of hydraulic cylinders were used to pivot 47 aluminum louvers on each side of the Innovation, Science and Technology Building. Each hydraulic cylinder is fitted with electronically controlled proportional valves and an electronic position feedback transducer that communicates the position of the cylinder and louver to a programmable logic controller.



has served as the mechanization consultant for several projects incorporating the latest methodologies in kinetic architecture and engineering. Our work demonstrates how the engineering of kinetic elements and mechanization consulting have progressed in recent years and how structural engineers can meet the challenges associated with integrating their structural designs with the mechanization elements necessary to make a modern structure move.

Retractable roofs and large operable walls or doors at sports stadiums have become relatively common in recent years. Sports fans have generally responded favorably to these elements because they offer protection from inclement weather when closed but make for a traditional outdoor experience in good weather when open. Advances in mechanization and power electronics helped to make these elements more practical and efficient to build than they had been in the past. Before these advances, synchronizing the motion of mechanical elements proved much more challenging, short of linking them together mechanically or structurally. Therefore, some of the earlier retractable roofs were designed in such a way that synchronization either was not necessary or, if necessary, was achieved by mechanical linking. In the 1980s advances in electronic controllers and position feedback devices or transducers made it possible for motor groups or hydraulic cylinders to be synchronized with relative ease. Architects and structural engineers, collaborating with mechanization engineers, then began integrating these advances into kinetic architecture in many creative ways.

In the past, a moving structure sometimes had to be designed to resist relatively large secondary loads from the mechanization system. Such loads may occur, for instance, if one side of a moving structure is out of position with respect to the other because of inaccuracies in the synchronization system. In a retractable roof, this asynchronous positioning would result in racking loads in the plane of the roof that would be resisted through the bracing system. In some cases, these loads exceeded the normal requirements for bracing of a static structure and resulted in a heavier overall structure. But with improved synchronization, the out-of-position tolerance can be held to a very small distance, on the order of 1 in. For a typical retractable roof spanning hundreds of feet on a sports stadium, this small difference in the positions of the two sides of the roof results in negligible distortion and secondary loads on the structure. This is just one of the ways in which advances in mechanization have helped lower the cost of kinetic elements and make them an attractive alternative for many owners.

Most modern stadiums with retractable roofs involve multiple panels that must move in sequence. Nearly every case involving multiple panels requires synchronization of multiple motor groups within a given panel, as well as motion control and collision avoidance with respect to adjacent panels. When multiple roof panels are involved, they are often designed to move in an overlapping fashion to a nested position or to part in the middle and move away from one another. Often, motion profiles must be followed so that adjacent panels can properly seal without interference as they come together.

In order to meet the challenges associated with kinetic architecture, the architect, the structural engineer, and the

mechanization consultant must carefully coordinate their efforts throughout the design and construction process. The architect typically determines the overall design concept from the top down, working with the structural engineer and the mechanization consultant, who in turn concurrently develop workable structural and mechanization concepts, along with spatial requirements. This holistic approach early in the process is necessary for a successful outcome. As the design progresses, the structural engineer and the mechanization consultant must communicate the limitations of their respective systems and coordinate their designs closely.

What is more, all stakeholders must understand the limitations of kinetic architecture elements and their intended operation. Oftentimes, environmental conditions limit the operation of a particular kinetic element. These limits may result from the time of year during which a particular sport is played or from the location

**IN ORDER TO meet the challenges associated with kinetic architecture, the architect, the structural engineer, and the mechanization consultant must carefully coordinate their efforts throughout the design and construction process.**

and climate of a given stadium. Usually, retractable roofs or large operable walls or doors may be opened or closed only under relatively mild wind speeds. Speeds of 30 to 40 mph are common limits for operating such features, although higher wind speeds have been accommodated. Where hurricanes or high winds are a possibility, an auxiliary system is commonly used to resist the associated wind loads. In these cases the roof or operable wall or door will have to be moved to a particular stowed position before being anchored. Typically, such tension devices as large turnbuckles or some other type of tension link are used. The structural engineer and the mechanization consultant must coordinate their efforts to determine the location of these devices and the loads they are to transmit.

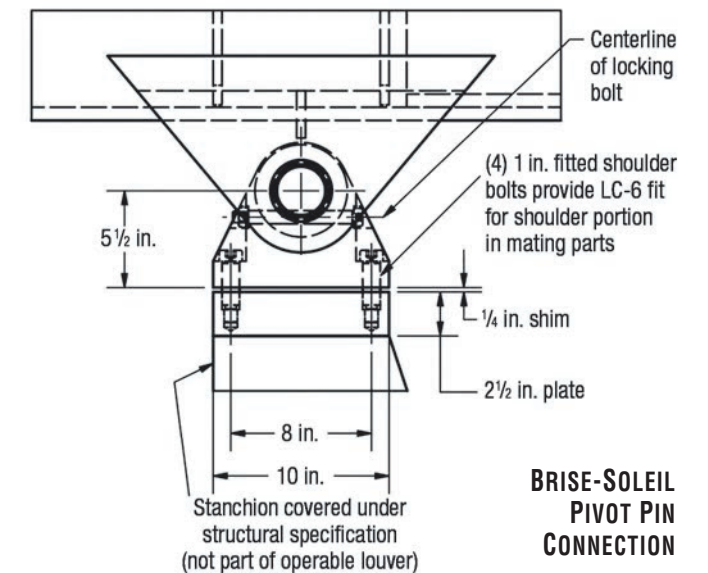

It is generally assumed that, in the event of a hurricane, one or more days of advance notice will permit at least one eight-hour shift during which workers can stow the kinetic elements. However, in the case of summer thunderstorms or microburst winds, there probably will not be adequate notice for moving the kinetic element to a stowed position in order to anchor it. Therefore, it is prudent to design the normal operating system in such a way that the kinetic element can be stopped safely at any point along its path of travel in winds up to a wind speed consistent with these types of weather events.

In recent years, H&H has worked with architects and structural engineers to develop many unique, groundbreaking designs involving movable bridges or buildings.

**O**NE EXAMPLE involves a striking architectural feature developed by the architect Santiago Calatrava for the Innovation, Science and Technology Building, located in Lakeland, Florida, on the campus of Florida Polytechnic University. (Read "Capturing Imaginations," *Civil Engineering*, March 2015, pages 48–55.) Completed in the autumn of 2014, the mechanized system involves an

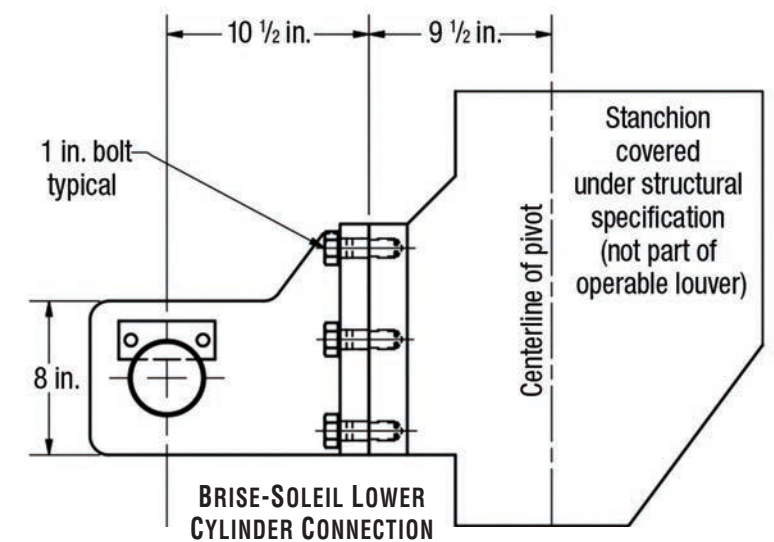



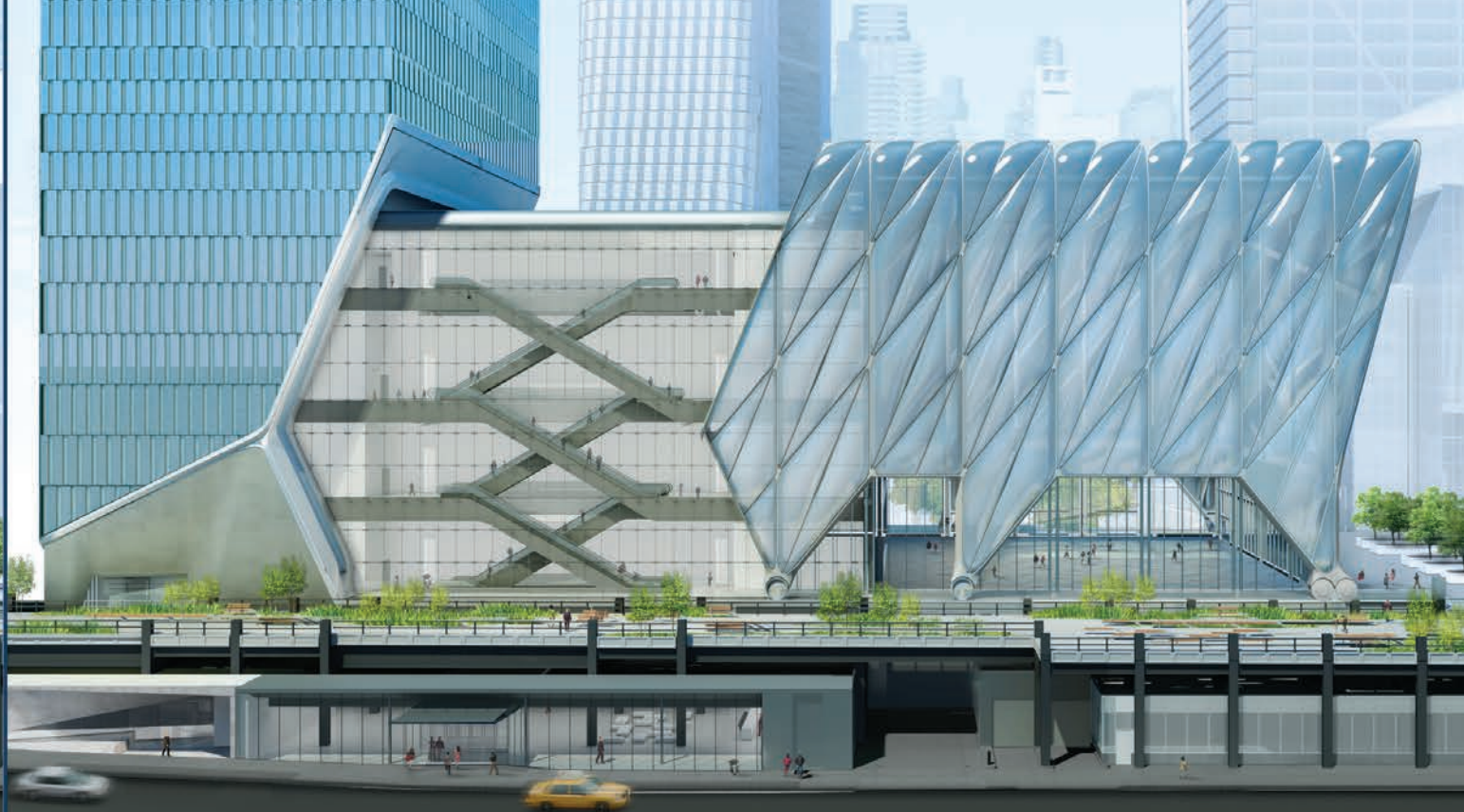

operable brise-soleil, or large sunscreen. The brise-soleil shades the expansive glass facade of the portion of the building known as the Commons. Over the course of the day, the brise-soleil tracks the sun's path through the sky. Although it was designed to be outfitted with solar panels to create a large movable solar array, budgetary considerations precluded such an arrangement.

The project succeeded in large part because of the close coordination on the part of Calatrava's office in New York City, the H&H mechanization team, and the structural engineer—Thornton Tomasetti, of New York City—during the design and construction process. A series of hydraulic cylinders were used to pivot 47 aluminum louvers on each side of the building. The louvers are designed to achieve the optimal balance of strength, weight, and architectural form. Each hydraulic cylinder is fitted with electronically controlled proportional valves and an electronic position feedback transducer that communicates the position of the cylinder and louver to a programmable logic controller (PLC). The PLC controls the valves so as to control the motion of the cylinders and synchronize them with all other cylinders on their side of the building. The individual control of each louver optimizes solar control and, if photovoltaic panels are installed in the future, will improve the efficiency of the solar array.

Because this installation is located in Florida, where hurricane winds are common, a latching system was developed to lock the louvers in the fully closed position during high winds. For intermediate winds, the PLC was programmed to automatically close and latch the louvers whenever wind speeds exceed 25 mph. However, the system is designed to operate within

**Currently under construction in New York City, the Shed is a six-story structure with a movable shell—a three-sided portal frame structure with one end that can be opened or closed. In its retracted position, left, the shell envelops the fixed building. When the shell is extended, right, it will double the Shed's footprint by enclosing an adjacent courtyard to the east.**

normal allowable stress levels at wind speeds up to 40 mph in order to accommodate higher wind speeds that may occur while the louvers are being closed. As is typical for most large-scale kinetic architecture elements, anemometers are used to monitor wind speed at all times and inform the PLC when the speed exceeds certain thresholds. Lightning strikes are monitored as well so that the louvers can be closed whenever lightning is detected and a thunderstorm may be approaching. During the design phase of the project,

close coordination on the part of all stakeholders was of cardinal importance in establishing the best balance of form, function, and cost.

The louvers' hydraulic control system includes multiple levels of redundancy. For example, the system features two independent hydraulic power units consisting of several motor and pump combinations. In normal operation, both units are running, with each controlling half of the cylinders. In the event of a failure of one hydraulic power unit, the other unit is fully capable of controlling all cylinders at slower than normal speed. Each hydraulic power unit includes several combinations of motors and pumps such that a failure of any motor or pump will not put that unit out of service. As a last resort, if a complete electric power loss occurs, a manual bypass system will enable all the louvers to lower to the stowed position and lock under the influence of gravity. As is the case with all large-scale kinetic architecture elements, the mechanization design required ample redundancy and contingency plans for such extraordinary events as power failures or normal breakdowns of electrical or mechanical equipment.

## THE SHELL will be moved by means of two rack-and-pinion-driven sleds running in U-shaped tracks mounted to the roof of the fixed building.

**A**NOTHER project is the Shed, a mixed-use arts and cultural center currently under construction as part of New York City's Hudson Yards development and slated for completion in 2019. The architecture firm Diller Scofidio + Renfro, in collaboration with Rockwell Group (both of New York City), is leading the project team, which includes Thornton Tomasetti as structural engineer and H&H as mechanization subconsultant. The Shed is a six-story structure with a movable shell—a three-sided portal frame structure with one end that can be either open or closed. In its retracted position, the shell envelops the fixed building. When the shell is extended, it will double the Shed's footprint by enclosing an adjacent courtyard to the east, creating an expansive ground-floor space for either enclosed or open-air arts and cultural events.

Approximately 125 ft tall, wide, and deep, the rolling shell will weigh approximately 8 million lb and be supported on six bogies, each having wheels 6 ft in diameter. Four of the six bogies will have two wheels, while the two most heavily loaded bogies, at the closed end of the portal frame, will have four. On either side of the movable shell, a pair of rails spaced 40 in. apart will create a 250 ft long runway. To equalize the loads on the wheels, the two-wheel bogies have been designed with a gimbal joint configuration, while the four-wheel bogies have been designed with a double gimbal

joint configuration with a pinned equalizer beam between each joint.

The maximum operating design wheel loads are 794 kips per wheel, and the maximum static design wheel loads are 921 kips per wheel. Large tapered roller bearings running on 25 in. diameter shafts are used to facilitate smooth rolling of the wheels.

The shell will be moved by means of two rack-and-pinion-driven sleds running in U-shaped tracks mounted to the roof of the fixed building. The sleds include a reaction arm and a sliding gimbal bearing system linking the moving building to the sled frame, which releases five degrees of freedom while allowing strictly longitudinal forces to be transmitted in the direction of motion. This linkage mechanism is necessary to allow relative movement between the fixed and the movable structures other than in the longitudinal direction of motion. Each sled is powered by six electric motors of 15 hp each driving the pinions through a planetary gear reducer. The extending shell will move at approximately 25 ft/min.

The shell also will include a series of eight operable wall sections that can be lowered for a completely closed event or hoisted to a raised position to lend an open-air feel. The winches used to operate the wall sections are mounted in the mechanical deck area within the shed roof trusses. The design of the rope-reeving system proved to be challenging because

DILLER SCOFIDIO + RENFRO IN COLLABORATION WITH ROCKWELL GROUP, BOTH



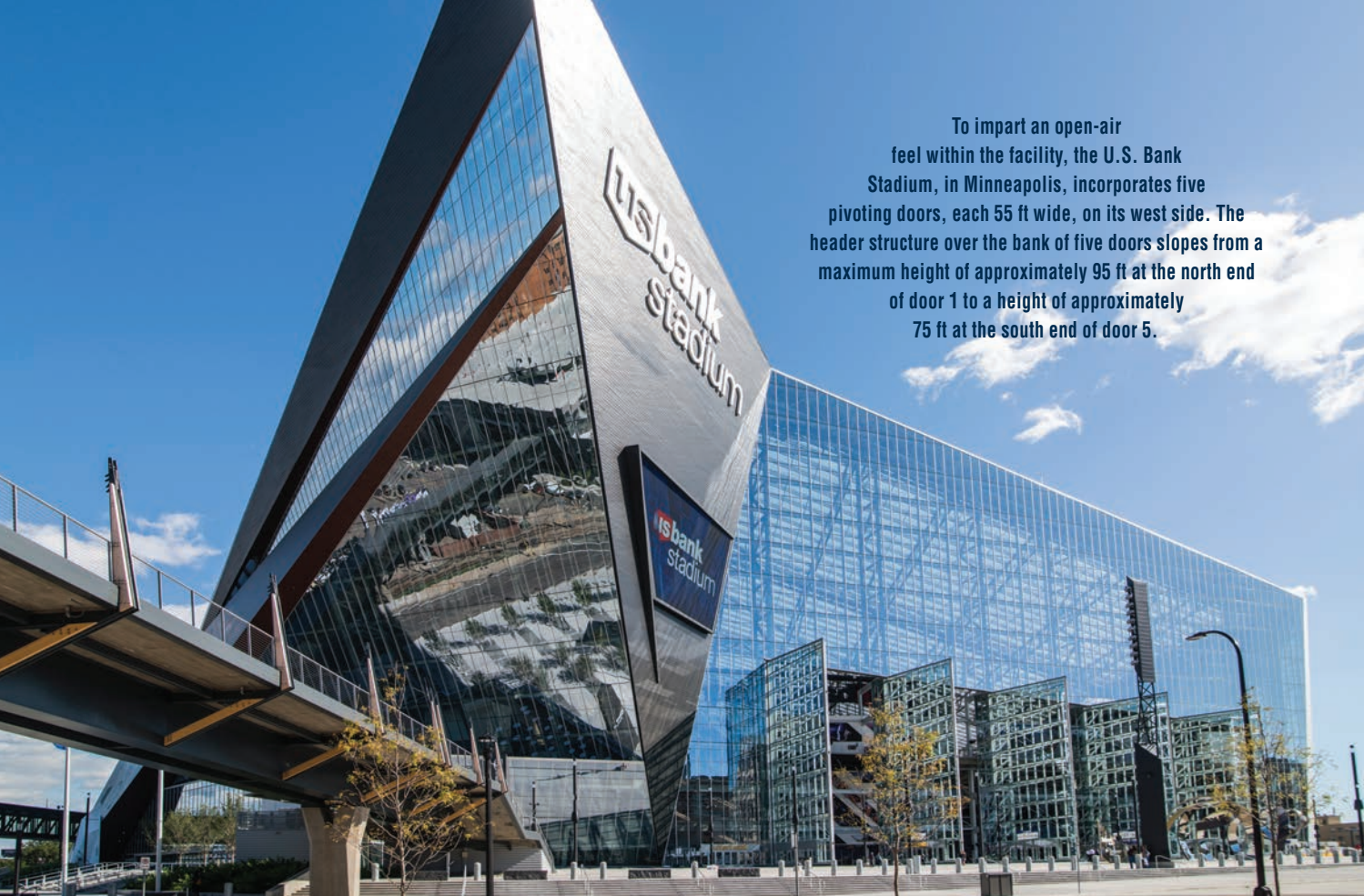

To impart an open-air feel within the facility, the U.S. Bank Stadium, in Minneapolis, incorporates five pivoting doors, each 55 ft wide, on its west side. The header structure over the bank of five doors slopes from a maximum height of approximately 95 ft at the north end of door 1 to a height of approximately 75 ft at the south end of door 5.

it had to be coordinated with many other systems located in the mechanical deck area, including the building maintenance system; the heating, ventilation, and air-conditioning system; and the entertainment staging equipment.

Three-dimensional building information modeling was used extensively to avoid clashes. The location of the winches and sheaves used to direct the ropes from the winches to the tops of the movable wall sections was closely coordinated with the architect and the structural engineer to ensure that the aesthetic characteristics of the Shed would be preserved and that the requisite loads imparted to the structure would be accounted for in the structural design.

**T**HE FINAL example comes from the U.S. Bank Stadium, which is owned by the Minnesota Sports Facilities Authority and is the home of the Minnesota Vikings. Located in Minneapolis, the stadium incorporates five

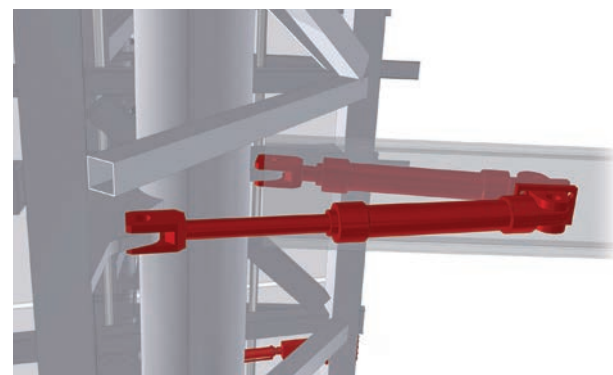

The most efficient way to swing the five large doors open 90 degrees was to use three pairs of hydraulic cylinders per door, *above*, operating in a push-pull manner. Actuators are used to lift the smaller egress doors, *below*, which operate when weather conditions preclude the use of the swinging doors.

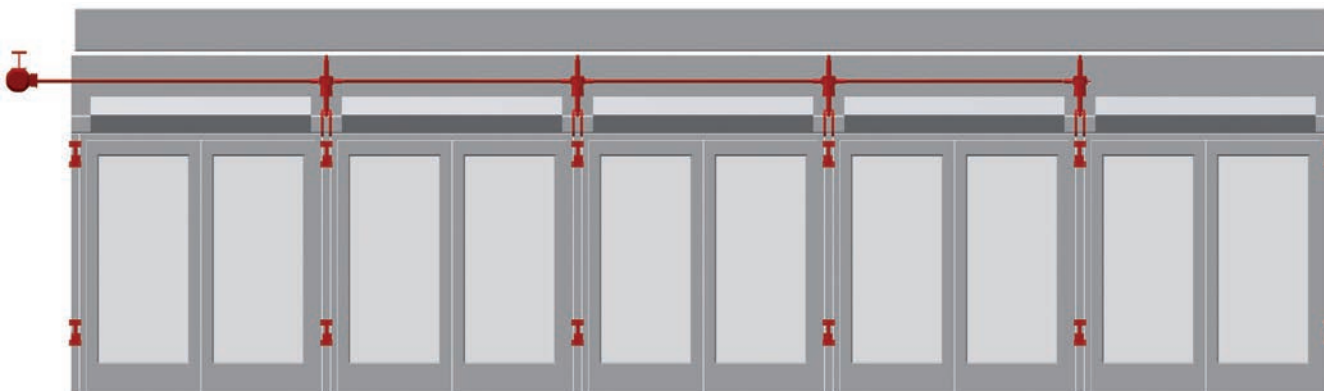

COURTESY OF U.S. BANK, TOP; HARDESTY & HANOVER AND THORNTON TOMASETTI, MIDDLE AND BOTTOM

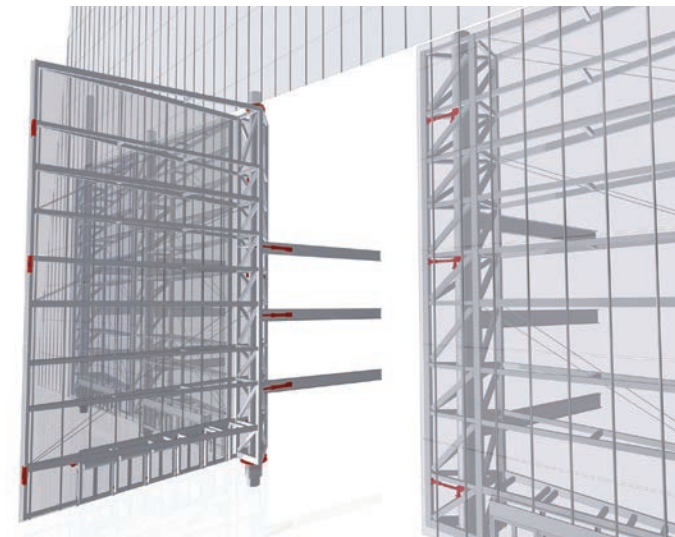

Turning cylinders and upper and lower pivot bearings move the large doors, and lock bars secure them during high winds or other extreme weather events, *above left*. Each door pivots about a fixed building column, *above right*, located approximately 5 ft from the north edge of the door.

pivoting doors, each 55 ft wide, on its west side. The header structure over the bank of five doors slopes from a maximum height of approximately 95 ft at the north end of door 1 to a height of approximately 75 ft at the south end of door 5. Each door pivots about a fixed building column located approximately 5 ft from the north edge of the door. The door pivot bearings were designed to be split so that they could be installed after the columns had been installed.

Led by the architecture firm HKS, Inc., of Dallas, the project team included Thornton Tomasetti as structural engineer and H&H as its mechanization consultant. During the design process, the team of mechanization and structural engineers recommended to the architect that the pivot location be centered on the door width in order to balance any gravity and wind loads, reducing the torque necessary to rotate and hold the doors in position about the pivot axis. This suggestion, however, presented problems architecturally, as it would have resulted in approximately 27.5 ft of door swing into the building, limiting the free movement of patrons and introducing other unfavorable architectural ramifications. The team ultimately decided to pivot each door closer to its edge in order to allay these concerns. However, this decision meant that the machinery would have to be designed to have a higher capacity to compensate for larger eccentric loads.

The most efficient way to operate the five doors entailed using three pairs of hydraulic cylinders per door operating in a push-pull configuration. Nested in the door frame itself, the cylinders transmit the torque-producing forces efficiently between the door frame and the fixed building framing. The system is designed so that the doors can operate in winds up to 40 mph and be held in any position in winds speeds up to 67.5 mph even with as many as two of the six cylinders out of commission.

When winds having speeds higher than 40 mph are expected or other unfavorable weather conditions exist, the

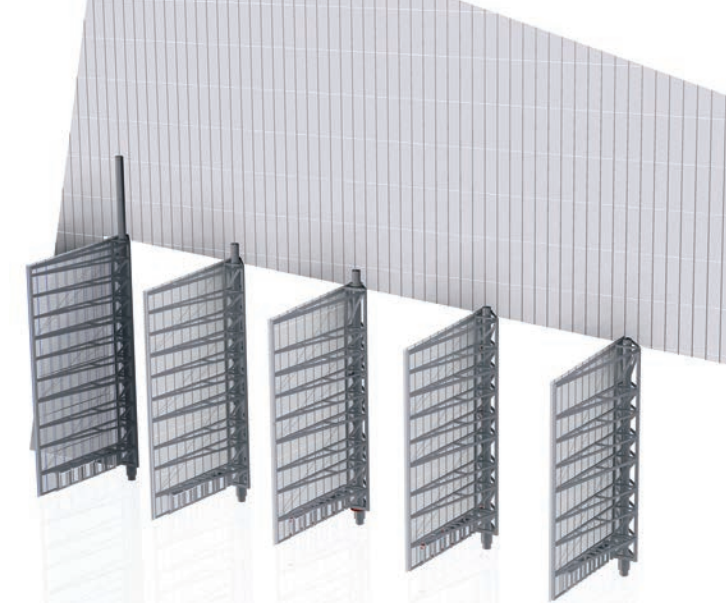

doors will be closed and latched by means of a series of lock bars located along the side jambs and at the head. Under such circumstances, a bank of entry doors on each pivoting door panel allows entry into the building. The banks of entry doors are raised slightly using a separate system of screw jacks to prevent the sills from dragging on the pavement as the doors swing open or closed, a 90-degree movement.

Exciting opportunities abound for expanding the functional and aesthetic quality of modern architecture through the use of kinetic elements. That being said, the success of any project involving kinetic architecture requires close coordination and cooperation on the part of all stakeholders throughout the process. It is important for the owner, the architect, and the structural engineer to work closely with the mechanization consultant to understand the operational limitations associated with the kinetic elements and to ensure the successful integration of these elements into the overall design.



*Brian Hamill, P.E., M.ASCE, is the chief engineer of the kinetic systems group of Hardesty & Hanover in New York City.*

#### PROJECT CREDITS

**Innovation, Science and Technology Building**  
**Owner:** Florida Polytechnic University **Architect:** Santiago Calatrava **Structural engineer:** Thornton Tomasetti, New York City **Mechanization engineer:** Hardesty & Hanover, New York City **Builder:** Skanska, New York City

**The Shed**  
**Owner:** The Shed, New York City **Architect:** Diller Scofidio + Renfro, New York City and Rockwell Group, New York City **Structural engineer:** Thornton Tomasetti, New York City **Mechanization engineer:** Hardesty & Hanover, New York City **Builder:** Sciam Construction, LLC, New York City

**U.S. Bank Stadium**  
**Owner:** Minnesota Sports Facilities Authority **Architect:** HKS, Inc., Dallas **Structural engineer:** Thornton Tomasetti, New York City **Mechanization engineer:** Hardesty & Hanover, New York City **Builder:** M.A. Mortenson Company, Minneapolis